

B I N D I N G

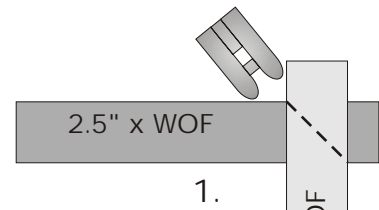

1. Cut your binding strips 2.5" x Width of Fabric (WOF). Cut enough to go around quilt PLUS 24". To join strips, lay two strips, right sides together and overlapping ends a little. Sew a diagonal line from inside corner to inside corner as shown in diagram #1.



2. Trim excess to a quarter inch seam allowance, diagram #2. Continue until all of your strips are sewn together.

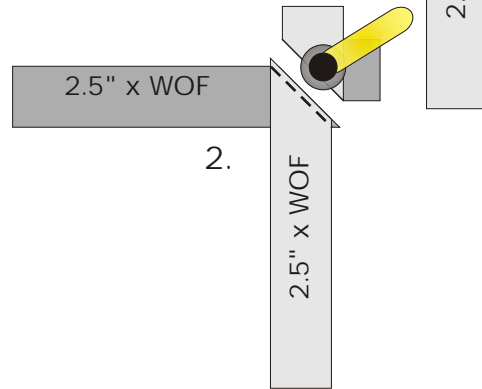

3. Press seam allowances to one side and trim any protruding ears.

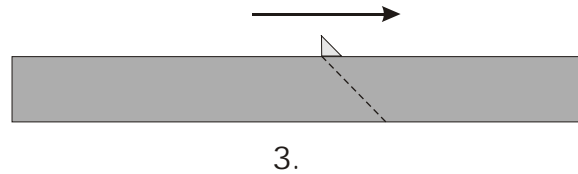

4. Press entire length, wrong sides together, matching raw edges.



5. Leaving a 10" tail, match the RAW edge of the binding up with the raw edge of the quilt. Sew $\frac{1}{4}$ " from the edge, through binding and quilt. (You may find a walking foot helpful here). Stop $\frac{1}{4}$ " from the corner.

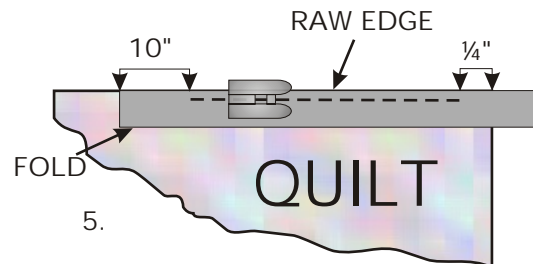

*You may sew a $\frac{3}{8}$ " seam, but you must stop $\frac{3}{8}$ " from the corner.

6. Fold binding up, aligning it with the vertical side of the quilt. Crease the 45 degree fold.

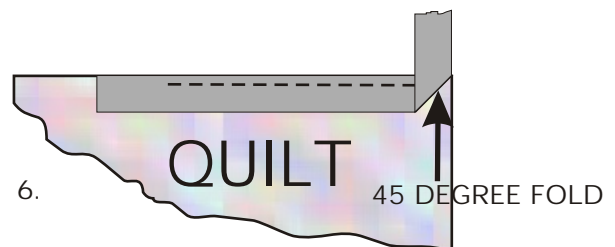

7. Keeping the crease, fold the binding straight down, aligning with the vertical edge. Crease. Starting at the corner, backstitch and sew $\frac{1}{4}$ " from the edge.



8. Continue all the way around the quilt, stopping and backstitching 12" from your starting point. Leave a 10"

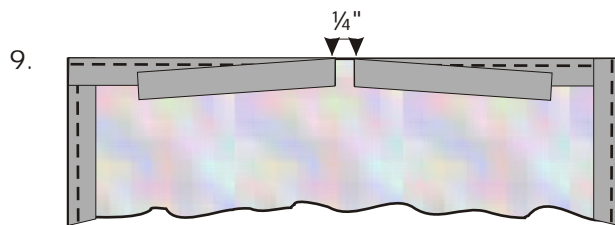

9. Lay the quilt flat. Line up your tails with the edge of the quilt. Fold the tails back, leaving a $\frac{1}{4}$ " gap between the folds. Crease these folds.

10. Open up one side of the binding. Line up the 45 degree line on your 6" square ruler with the crease you made in the binding. Make sure the corner of the ruler is lined up with the horizontal fold in the binding. Draw a line from the raw edge across the intersecting folds to the other edge.

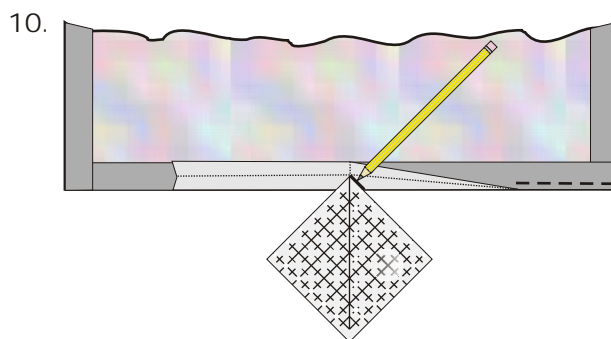

11. Be sure the line goes directly through the intersecting folds.

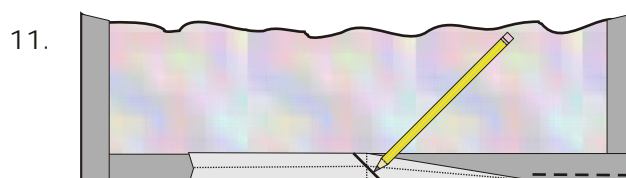

12. Trim the tail off the binding $\frac{1}{4}$ " from the drawn line.

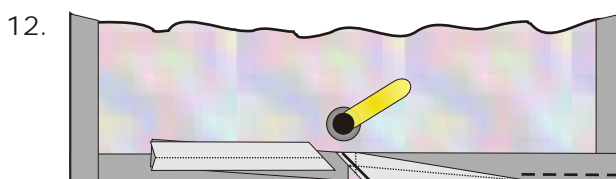

13. Now open the other end of the tail and draw a diagonal line. ****BE SURE YOUR LINE IS LEANING IN THE SAME DIRECTION AS THE FIRST LINE!****

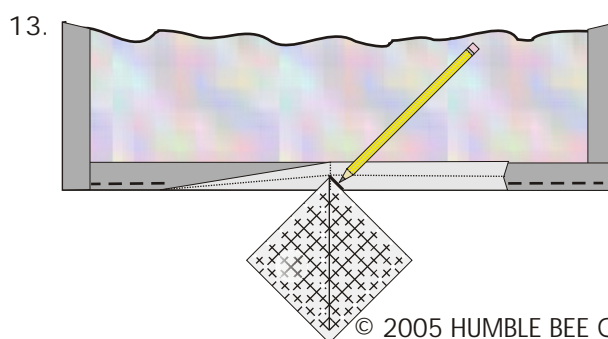

14. Trim the tail off the binding $\frac{1}{4}$ " from the drawn line. Be sure you are trimming the end off.

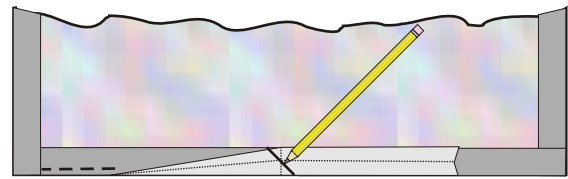

15. Match the two ends that you just trimmed with the right sides together. Be sure not to twist the binding.

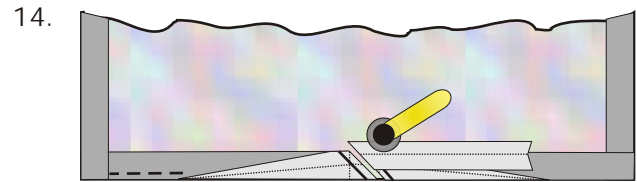

16. Match the ends and pin through the intersecting folds to keep the binding aligned. Sew a $\frac{1}{4}$ " seam.

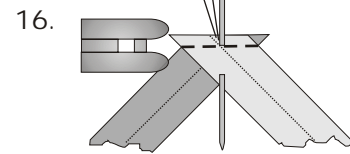
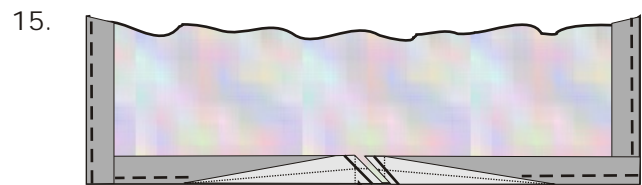

17. Press the binding flat against the quilt, pushing the seam allowance to one side. Sew the gap up, backstitching at both ends.

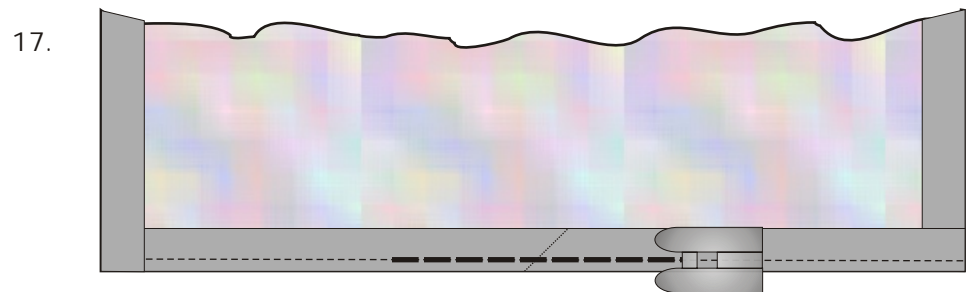

18. Now fold the binding around to the back of the quilt and hand stitch the folded edge down. You should have a nice flat binding and your final connecting seam should not stand out.